

# SCaT 2001

6-8 November 2001

World Trade Centre, Bombay

[Click Here !](#)

[October 2001 Issue](#)

[Editor's Scatview](#)

[Mailbox](#)

[Indian News](#)

[International News](#)

[Reverse Path](#)

[Convergence News](#)

[Focus : SCaT Tradeshaw](#)

[SCaT Financials](#) **Now!**

[SCaT Business News](#)

[Compulsory Addressability ?](#)

[B4U Movies Launch](#)

[Cable Labs Docsis 2.0](#)

[Convergence - BBC](#)

[Star Pursuing DTH ?](#)

[Fiber Optic System](#)

[Channel News Asia](#)

[Asianet First CATV](#)

[Communication Industry](#)

[Events](#)

[Dish Doctor](#)

[Channel Guide](#)

## CATV FIBER OPTIC NETWORK SYSTEM DESIGN

*PART III - A Practical Guide To Fiber Optic System Design*

*The third part of this series of articles takes a closer look at the practical aspects of Fiber Optic System design. It concludes with an actual system design request that we have received from a reader.*

Part - I of this series of articles provided a basic overview on the Key Components of a Fiber Optics. Part - II discussed layout and other details relating to Fiber Optics CATV systems. This article - Part - III will focus practical system design and Layout.

Infact, this article was inspired by an actual query that we received from one of our readers in Southern India. This query will be discussed in detail at the end of this article, as a typical case study.

### BASIC SYSTEM DESIGN: OPTICAL POWER

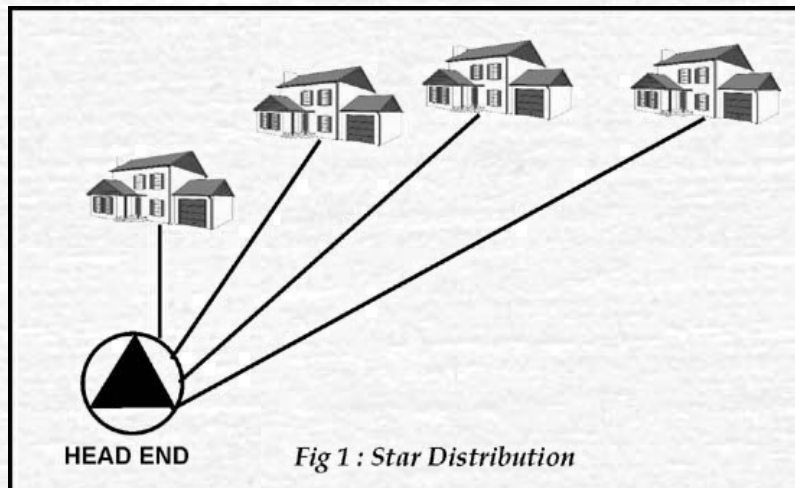

As explained in the earlier articles, the Optical Signal is generated by a laser diode inside the fiber Optic transmitter. The amount of light output available is measured in dBmW. This indicates the extent to which the optical output is greater than a 1 milli Watt Optical Output, which is taken as the 0 dB reference.

An out-put signal of 3 dBmW indicates a power twice that of the 0 dB signal. Hence, 3 dBmW = 2 milli Watts.

An output of 6 dBmW will be = 4 milli watts.  
Similarly, 9 dBmW = 8 milli Watts and 12 dBmW = 16 milli Watts.

The output power keeps doubling for every 3 dB increase. Hence, as you can imagine a 12 dBmW Fiber Optic Transmitter will be substantially more expensive than a 9 dBmW transmitter.

### CABLE LOSSES:

As explained in the earlier part of this article, fiber optic cable has a loss of 0.35 dB per KM @ 1310nm. However, there are other factors that add in a small way to the theoretical cable loss. Let us examine each of these in detail.

### SAG LOSS:

When cable is laid overhead, even when supported by messenger wires, it sags hence the actual length of cable between two points is longer than the theoretical measurement. This amount is referred to as Cable Sag. System designers often build in an extra 2% to 5% length to compensate for cable sag.

Even cable laid underground is not laid ruler straight but zigzags within the conduit. Conservative system designers often account for an additional 2% cable length for cable "sag", when the cable is laid underground. Hence in practical system design, we need to add 2% extra cable length, to account for cable sag.

### SPARE CABLE LOOPS

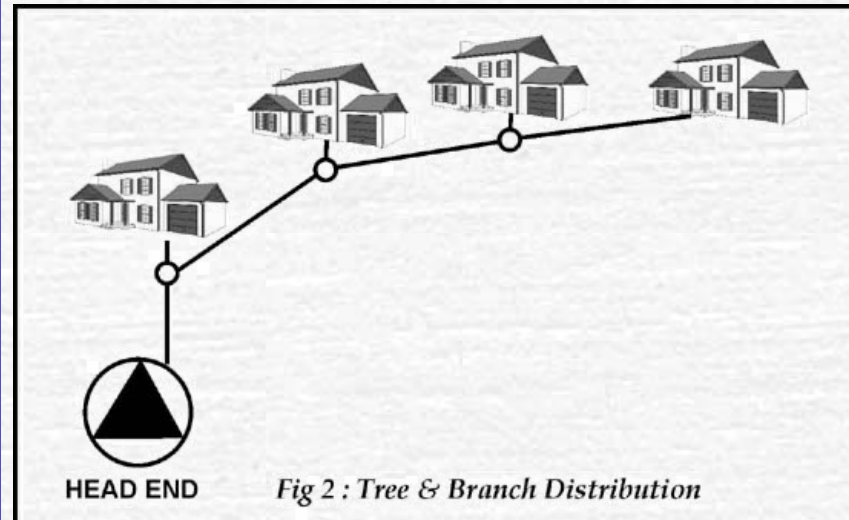

If optical cable is damaged it needs to be joined together by splicing. The splicing process requires an extra length of cable to make the splice. To accommodate these contingencies, in the field extra lengths / loops of cable are maintained at regular intervals. As an example loops of a minimum of 10 meters and a maximum of 100 meters are maintained coiled, for every 2 Km stretch.

### SPLICE LOSSES FUSION & MECHANICAL

### SPLICES

Proper cable splicing (joints) is critical for satisfactory installation and operation of a fiber optic network. Splicing can either be done mechanically or automatically using a fusion splicer. Mechanical splicing requires the Fiber Optic Technician to have a high degree of skill in making a splice. A bad mechanical splice may have a loss of upto 1 dB. A good mechanical splice will typically have a loss of 0.1 dB. These losses are high especially when you consider that 1 Kilometer of fiber optic cable has a loss of 0.35 dB ! A high quality fusion splice, made on an automatic fusion splicer would have a loss of 0.05 dB or even less!

### NUMBER OF JOINTS

Fiber optic cables are usually supplied in 2 Kilometer length drums. Hence, each drum will require one splice at each end i.e. two splices over 2 kilometers or on an average of 1 splice of 0.05dB (if a fusion splicer is used) per Kilometer. Considering all these losses, system designers typically add a margin of extra losses. These are in addition to the theoretical loss of 0.35 dB per Km. Considering the extra losses, it is prudent to design your system with a cable + splice loss of @ 0.4 dB per kilometer or a worst case of 0.45 dB per kilometer.

### OPTICAL LOSSES:

The optical output from the transmitter will be attenuated by the distribution system before it reaches the receiver. As explained in the earlier Part - II, it is recommended that the Fiber Optic receiver, receives at least 0 dBmW. This implies that the Fiber Optic system designer has a "Budget" of the transmitter power output that he can use to compensate distribution losses in the optical splitters, optical connectors and splice loss.

### LOSS / safety MARGIN:

Again it is a good practice to work out a system design that provides for a 0.4dB loss margin. This implies that even if on the field, the cable length or the splice losses are more than what appears on paper, the system will still work perfectly. The loss margin also compensates for long term (over the years) deterioration of the fiber optic cable characteristics, lower laser transmitter light output due to aging, non perfect splices, etc.

Putting all this together we can express this as a simple equation:

Transmitter power required =  
Splitter Loss + Cable Loss + Splice Loss +  
0.4 dB Safety Margin + 1 dB Connector Loss

### PRACTICAL DISTRIBUTION TOPOLOGIES



Part - I of the article showed the Block diagram of various Fiber Optic systems such as a tree and branch layout & a Star Layout. While in principle either of these can be used,

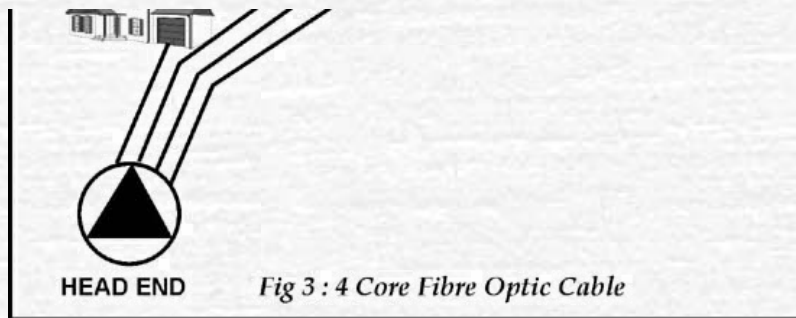

modern practice is to adopt a Star layout. A basic star configuration is shown in figure - 1. It may seem unusual or even a wasteful use of multi-strand fiber optic cables. However, the system is much easier to install and less prone to damage and breakdowns if the optical splitters are all located inside the head end.

The transmission losses will be same whether the various nodes are feed, each with their own dedicated strand of fiber or if as in figure - 2, the splitters are all installed outdoors on the same strand on Fiber Cable.

**CABLE CONFIGURATION:**

Fiber Optic (FO) Cable is almost never available with a single core or even with two cores. A 6 to 8 core configuration is generally the minimum available. 12 & 24 Core FO cables are the norm. The higher number of fiber strands within a cable provide the fiber optic system designer greater flexibility. The multi-Core cable provides a means to implement a distribution system as shown in figure - 3 which uses a star structure and every node is serviced by a dedicated fiber core.

Extra cores can also be reserved for the Reverse path. However, this article will focus only on the Forward Path system design. The Reverse path design would be best addressed in a separate future article.

**PRACTICAL SYSTEM:**

Let us design a distribution system for a head end that needs to distribute its signals to four franchises. The first is located 3 KMS from the head-end the 2nd at 6 Kms the 3rd at 9 Kms and the last at 12 Kms. The layout for this is shown in figure 3. This case is infact, based on an actual query that we received in our Dish Doctor column from Monarch Vision, Always, Kerala. As per the recommended procedures let us install all the optical splitters inside the head end. To get four optical outputs, one for each node, 3 nos. of two way splitters are required. This is show in the system design diagram in figure 4.

As indicated in part - 2 in this series of articles, the optical splitters are available with various output ratios. Table - 1 indicates these ratios both in percentages and in dB.

**OPTICAL SPLITTER OR TAPOFF?**

A wide range of Tapoff and Splitters are available for RF Coaxial cable distribution. In general, a splitter divides the incoming signal into approximately equal outputs. On the other hand a Tapoff passes most of the signal unhindered from input to output. The Tapoff branch provides a substantially attenuated output (typically -10dB to -20 dB).

For fiber optic distribution, typically two way devices are used. However, both outputs of these need not be equal. These devices are available in various ratios of optical splits. This is shown in Table 1. Since the optical outputs of these devices are not equal, even though they have only two outputs, they are referred to either as optical tapoffs, optical taps, optical couplers or even optical splitters. All these terms refer to the same device.

An optical Tap / splitter costs approximately Rs 20,000 each, irrespective of the Loss ratio. Optical taps are available either as pigtailed, or with connectors. A pigtail is an open ended Fibre Optic strand, and needs to be spliced, to integrate it into the system. A connectorised Splitter, costs more & the connector ( 0.5 db per connector pair)loss will have to be added when designing the system, but it adds the convenience of rapid inter-changeability.

**TRANSMISSION OR ATTENUATION?**

Care should be taken when reading the optical tap ratios provided by the manufactures. Some manufactures quote the light transmitted. Hence, a 40:60 tap would imply that the first output transmits 40% i.e. it attenuates 60% of the incoming light. Other manufacturers quote the attenuation i.e. when they refer to a 40:60 tap, the first output attenuates 40% and transmits 60% of the light!

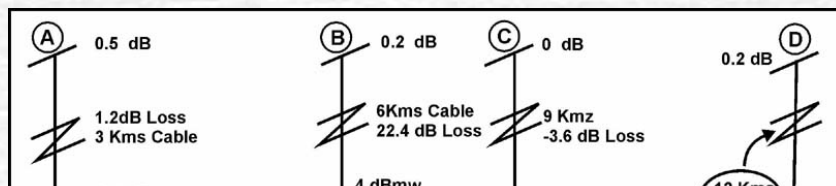

While both methods are correct it is important for the designer to understand the data sheet that he is referring to. To eliminate such confusion, figure 4 in

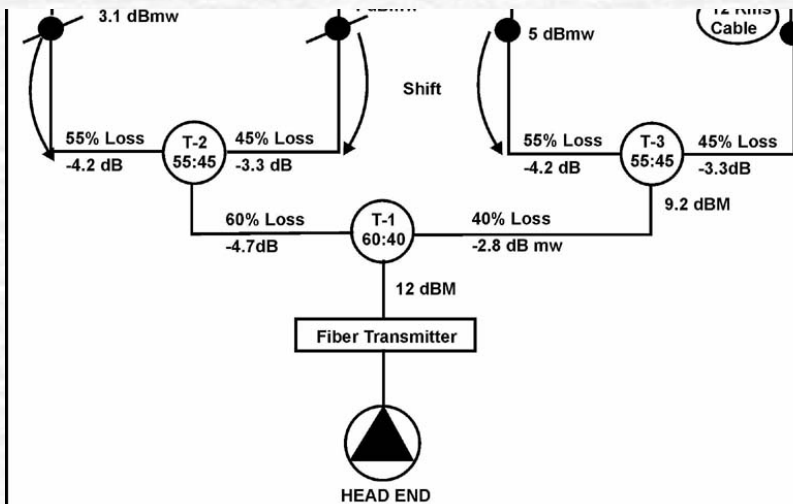

Figure 4 : Optical Loss Calculations for Figure 3.  
All Optical Splitters Located At the Head End

our practical example below clearly states 60% loss or 40% loss. It is necessary to keep in mind that the losses quoted in dB, in Table I include practical losses in real world optical splitters. The figures indicated in Table I are higher than the theoretical minimum loss.

Despite this, the losses in an optical splitter vary from manufacturer to manufacturer and even piece to piece. While the figures in Table 1 are representative, it is best to consult the specific manufacturers data sheet.

Variations of upto 0.3 dB are possible from the figures quoted in Table 1. Infact, most optical splitters are delivered with their loss measurement print out which is the best reference. For distribution, the splitters' loss ratios are indicated in figure - 4 were used.

Further, for design, the following assumptions were made (similar assumptions can be made while designing any other Fiber Optic system):

Cable attenuation = 0.4 dB per Kilometer. Actually cable attenuation is 0.35 dB / KM but an additional 0.05 dB per KM of splice loss is also added since it is assumed that the cable will be fusion spliced (Joint ) approximately once every Km.

#### CONNECTOR LOSS:

A connector insertion loss of 0.5 dB per connector (pair) is to be designed in. Of course, since a connector (pair) yields a 10 times higher loss than a splice, the connector is avoided as far as possible. However, a connector will be necessary where the Fiber Optic cable meets either the transmitter at one end or the receiver at the other.

Also, as mentioned earlier a 0.4 dB Loss or Safety Margin is built in.

#### LOSS CALCULATIONS:

Referring once again to Figure - 4 we can calculate the total loss.

Let us assume a Fiber Optic transmitter power of 12dBmW. Referring to the system design in Figure 4; this optical power is divided by splitter T1 into 2 parts viz: 60% (-4.7dB) loss and a 40% (-2.8dB) loss. The conversion of % to dB is taken from Table 1.

After attenuation in T1 of 4.7dB the signal is feed to T2 which is a 55:45 optical splitter /coupler. The higher loss ( -4.2dB) output of T2 yields an optical power output of:  
 $12 - 4.7 - 4.2 = 3.1 \text{ dBmW}$ .

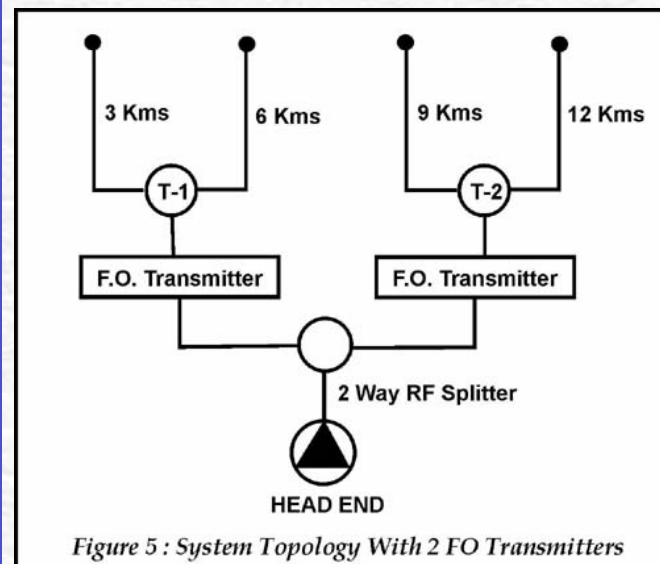

Figure 5 : System Topology With 2 FO Transmitters

This optical signal passes through 3 Km of cable before it arrives at termination point A (The 3 Km of cable will attenuate the signal by a further :  
 $3 \times 0.4 = 1.2 \text{ dB}$

providing a optical output signal of  
 $3.1 - 1.2 = 1.9 \text{ dBmW}$ .

We now have to account for the connector loss of 1dB. This will yield a final output at termination point A of:  
 $1.9 - 1 = 0.9 \text{ dB}$ .

Accounting for a safety loss of 0.4 dB, finally yields 0.5dB at the Fibre Optic receiver at Point A.

This is more than 0 dB.

As indicated earlier in the article the optical receiver must receive a light output of atleast 0dB. Since 0.4dB is more than 0dB, termination point A will receive an adequate optical signal level even when a worst case extra 0.4dB of loss margin is accomodated.

The loss calculation for the branch feeding point B is: 12 dB Transmitter output - 4.7dB T-1 Splitter Loss -3.3 dB 2nd Splitter loss - 6Kms Cable Loss@0.4 dB per Km - 1dB connector Loss, ie:  
 $12 - 4.7 - 3.3 - 6 \times 0.4 - 1 = 0.6 \text{ dB}$ .

This yields a signal of  $0.6 - 0.4 = 0.2 \text{ dB}$  at Point B ( Fig3) even after adding a worst case extra 0.4dB of loss / safety margin. The loss calculation for the branch feeding point C is:  
12 dB Transmitter output - 2.8dB T-1 Splitter Loss -3.3 dB T-3 Splitter loss - 9Kms Cable Loss@0.4 dB per Km - 1dB connector Loss, ie:  
 $12 - 2.8 - 4.2 - 9 \times 0.4 - 1 = 0.4 \text{ dB}$ .

This will still ensure a 0 dB signal received at point C even when a worst case extra 0.4dB of loss margin is kept aside. Similarly, the loss calculation for the branch feeding point D is:  
12 dB Transmitter output - 2.8dB T-1 Splitter Loss -3.3 dB T-3 Splitter loss - 12Kms Cable Loss@0.4 dB per Km - 1dB connector Loss, ie:  
 $12 - 2.8 - 3.3 - 12 \times 0.4 - 1 = 0.6 \text{ dB}$ .

This will still ensure a 0.2 dB signal received at point C even when a worst case extra 0.4dB of loss margin is kept aside.

### **RESULT:**

The system in Figure - 3 would require a 12 dBmW out put optical transmitter. Optical transmitters with these power are easily available in 1310 nm systems. Based on prevailing prices a suitable product would cost Rs. 3 Lakhs or 4 Lakhs if it is of imported origin. A similar product from a local manufacture would cost substantially less. Optical receivers could range in cost from Rs 30,000 to Rs 80,000 each.

### **FIBRE OPTIC TRANSMITTER COSTS**

The cost of a FO transmitter varies substantially with the output power. Table-2 provides indicative figures of the cost of 1310nm FO transmitters, from Motorola USA. The maximum power output available from Motorola (and most other manufactures) in 1310nm wavelength transmitters is 13 dBmW. For higher power outputs, one needs to move to 1510nm wavel-ength systems. These provide outputs as high as 24dBmW, but the cost rises to an almost prohibitive Rs 20 Lakhs !

### **AN ALTERNATE APPROACH**

It will be observed that the Optical transmitter costs increases rapidly, for higher optical output powers. Also, a maximum power of 13dBmW can be obtained, without moving to prohibitively more expensive 1510 nm FO transmitters. Keeping this in mind, FO system designers often utilise systems that use multiple lower power transmitters at the Head End, instead of a single high powered transmitter. Such an approach has the advantage that if a FO transmitter fails, only a part of the system, and not the entire system will be affected. Such a configuration is shown in figure 5. The system design in figure 5 uses only 2 splitters, and 2 FO transmitters. In India, we already have systems that deploy 10 Fiber Optic transmitters & have 40 Fiber Optic nodes, covering an entire city !

### **CONCLUSION:**

It is hoped that this article will help dispel fears that fiber optic system design is a black art and can be done only by well heeled Engineers. But then, which of us 5 years ago, would have felt comfortable installing and maintaining 750 MHz CATV networks with a reverse path?

 [Email Us](#)

*Updated On The 10<sup>th</sup> Of Every Month*