

[October '2000 Issue](#)
[Editor's Scatview](#)
[Mailbox](#)
[Indian News](#)
[International News](#)
[Focus : SCaT Tradeshow](#)
[Entertainment 2000](#)
[Convergence News](#)
[GI At SCaT 2000](#)
[Cable TV In Pakistan](#)
[Zee In Turmoil](#)
[ESPN & MEN Part Ways](#)
[Cable Act Amended](#)
[Channel News Asia](#)
[Star Buys Hathway](#)
[An Olympic Mess](#)
[Asianet In Turmoil](#)
[Digital CATV](#)
[Zee - MGM Movies](#)
[Interactive TV For India](#)
[Channel 9 Gold](#)
[Events](#)
[Dish Doctor](#)
[Channel Guide](#)

SETTING UP THE HEADEND

We continue to receive request from readers for details on how to set up a Cable TV Headend. SCaT revisits the topic.

INTRODUCTION

A Cable TV Headend is the heart of the network and the source of all signals. A considerable amount of funds are invested in the Headend and the network owner needs to keep in mind both, his existing needs as well as project and consider his future requirements.

NUMBER OF CHANNELS

The first question that comes to mind is to determine the number of channels that are planned both initially as well as a year or two later. A Headend in a small town may be content with an initial outlay for 12 channels, with a future plan to upgrade it to 24 or maximum 36 channels. For a cable network in a metropolitan area, 36 would probably be the minimum number of channels required at start-up with a capability to increase it to almost 60 channels.

Once a decision is taken on the number of channels, a suitable set of modulators need to be procured. Lower cost modulators suitable for upto 36 channels could be used by the smaller network.

However larger networks would have to purchase premium products at a higher price. **SYSTEM**

BANDWIDTH

Since each Cable TV channel below 300 MHz occupies a channel bandwidth of 7 MHz (above 300 MHz the channel bandwidth is 8 MHz), the decision on the number of channels will also effect the cost of distribution hardware. Table 1 indicates the number of channels and the corresponding bandwidth required to support these channels. Table 1:

No. of Channels	Bandwidth
26	230 MHz (Bands I & III only)
36	300 MHz
55	450 MHz
68	550 MHz
107	860 MHz

Note: The number of channels listed above assumes use of all skip channels as well as hyper band channels within the relevant frequency band. However, the figure excludes the use of any channels within the F M radio band of 88 to 108 MHz. (i.e. Channels Z+1, Z+2, & S-1)

CHANNEL HARDWARE

Each channel incorporated on a system must utilise one modulator. A satellite receiver will be required to be paired with each modulator, for every satellite channel that is to be received and re-transmitted on the cable network. An analog satellite receiver would be required for each free-to-air analog channel such as Zee TV or SET.

A digital satellite receiver would be required for reception of free-to-air digital channels such as Sri Adhikari Brothers, Fashion TV, etc. Encrypted (Pay) digital channels such as the STAR bouquet require their proprietary digital IRDs (Integrated Receiver-Decoders). These are only available through the channel or its authorised distributor.

DOORDARSHAN

A recent notice by the government has made it compulsory for every cable network in the country to carry atleast 2 Doordarshan channels on the prime band i.e. channels E2 to E4 and E5 to E12. Further, the notice requires that the Doordarshan channels **MUST** be received via satellite and not terrestrially, before they are carried on the network.

The satellite reception requirement by the government has been made to ensure that cable subscribers receive a ghost free picture of the Doordarshan channels. The requirement to carry it on the prime band ensures that every cable subscriber, even those with a B&W TV and a mechanical tuner, will receive these Doordarshan channels.

Further the cable network is not permitted to utilise the frequencies at which Doordarshan locally broadcasts its terrestrial channels.

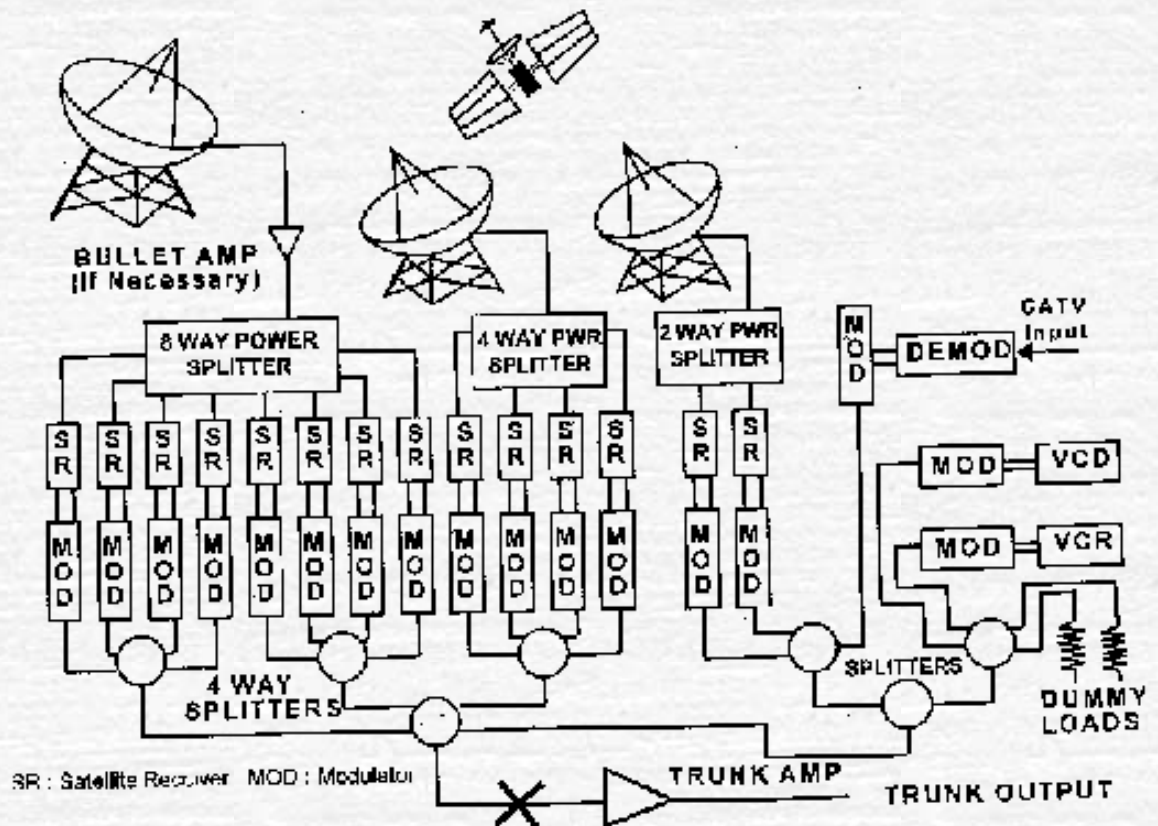

DE-MODULATOR

Several networks often receive a particular channel from another cable network and re-transmit it on their network. To accomplish this it is necessary to first demodulate the incoming channel to its separate audio and video components. These audio and video components can then be fed to a modulator and integrated on the network like any of the other channels. Often networks employ a simple Settop converter to obtain the audio and video components.

A demodulator is actually the correct solution as it will also provide the following features :

- 1) Re-start on the pre-set channel after a power failure.
- 2) Is usually available in a rack mount enclosure.

INTEGRATION

Figure 1 is a detailed block diagram for integrating a number of channels at the Headend. While the block diagram is self explanatory, certain issues need to be examined closely to ensure optimum

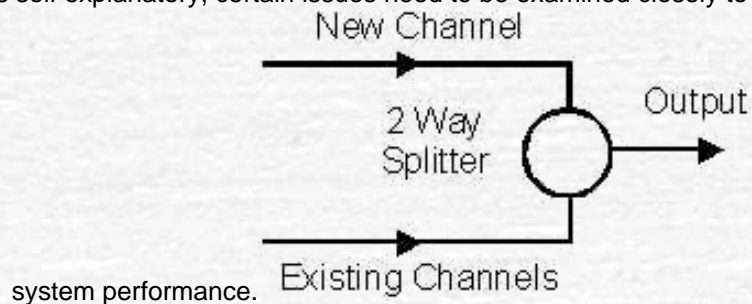

AV CARRIERS

It can now be safely assumed that almost every network in the country utilises adjacent channel modulators only. Alternate channel modulators are now almost completely obsolete. In an adjacent channel modulator, the level of the audio carrier needs to be set 18 to 20 dB below the level of the video carrier. It is important to note that the audio level cannot be measured accurately using an analog signal level meter (FSM). A digital FSM or ideally a spectrum analyser is required to properly measure and adjust the relative levels between the audio and video carriers of the modulator. If you do not have the necessary equipment, it is best not to tamper with the factory adjustments.

If the audio carrier level is set too low, it will result in a poor audio signal to noise ratio which will result in an audible background hiss on the channel. If the audio carrier level is set too high, it is likely to distort the picture of the NEXT channel i.e. a high audio carrier level on a channel 7 modulator could distort the channel 8 picture.

FREQUENCY AGILE MODULATORS

Frequency Agile Modulators allow the user to set its output frequency. This facility is almost always welcome but carries with it the following 2 penalties.

- A Frequency Agile Modulator typically has a poorer C/N (Carrier to Noise) ratio than a fixed channel modulator of a similar quality.
- A Frequency Agile Modulator is more expensive than a similar, Fixed Frequency Modulator.

Considering the above, the ideal solution is to provide for 1 or 2 Frequency Agile Modulators within a Headend, to serve as stand by or service modulators. These can be pressed into service immediately incase any of the other modulators fail. Use of all modulators in the Headend which are frequency agile will not only increase the system cost but will also tend to provide poorer C/N performance for the Headend.

MODULATOR OUTPUT LEVELS

We are often approached with queries from readers on the optimum setting of modulator R F output levels. The maximum R F output level of a Modulator is usually specified by a manufacturer (e.g. 105 dBu). It is always good practice to actually set your modulator output level atleast 2 to 3 dB less than the maximum specified level. This will also reduce, somewhat, the modulator distortion. Further it will assist in easier set up of the output "slope" as well shall see later.

CHANNEL COMBINING

The R F outputs from each modulator need to be combined together to form a single output signal at the Headend. A channel Combiner provides the solution. The Combiner is usually a passive device consisting of an array of Splitters and sometimes channel filters.

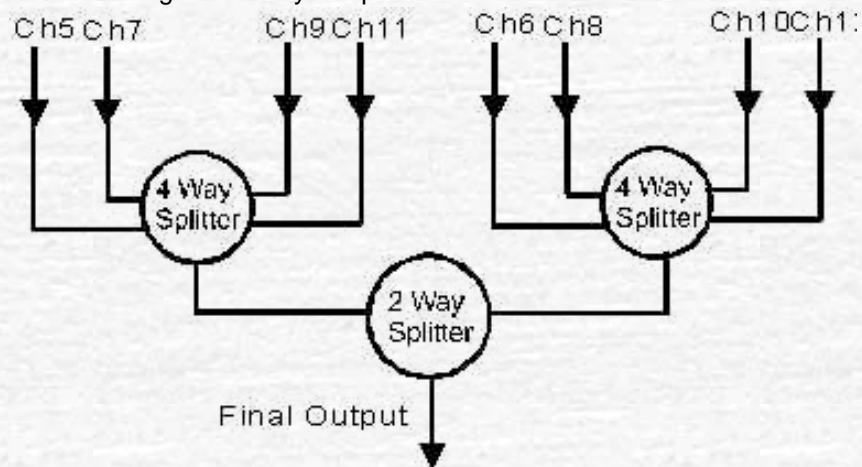

Some manufacturers offer an "Active Combiner" which besides the Combiner also includes a CATV amplifier built-in, to provide a high output level. Channel Combiners are sometimes designed to combine only specific channels because they incorporate filters that will suppress any out of band signals at each of the inputs. If your Headend already uses such a Combiner and you plan to add an extra channel that is not included on the Combiner, this can be done simply by using a 2 way Splitter in reverse. This is shown in Figure 2.

Just as a Splitter can divide an incoming signal into 2 or more outputs, it can also be used in the reverse direction to combine 2 or more channels each of which is at a different frequency. The same principle can be used to combine any number of channels.

Figure 3 shows the use of two 4 Way Splitters + a 2 Way Splitter to combine 8 channels.

Similarly Figure 4 indicates a scheme of 4 numbers 4 Way Splitters + a 2 Way Splitter to combine 14 channels. You will observe that this is an unsymmetrical combination. As we shall see shortly, some precautions need to be taken while adjusting signal levels but there is no need to configure a perfectly symmetrical combination of Splitters, for combining channels. You can also arrive at your own combination of Splitters to mix the desired number of channels.

Ideally, alternate or widely separated channels should be fed to the same mixer. As an example, channels 5, 7, 9 and 11 could be fed to one 4 Way Splitter and channels 6, 8, 10 and 12 to another 4 Way Splitter. Even if this is not done, the performance will not be degraded significantly.

However it is important that any unterminated port of the mixer (e.g. a 4 Way Splitter is used but only

3 channels are fed into it) must be terminated with a 75 Ohms dummy load. Not terminating the unused port, leads to significant deterioration in the isolation characteristics between inputs. Typically a good Splitter provides an isolation of more than 20 dB but if any port is unterminated, the isolation drops drastically to 8 to 10 dB.

LEVEL SETTING

The most critical and important aspect of setting up a Headend is to correctly set the levels of each of the channels. Figure 1 indicates the complete block diagram of a multi channel Headend. The signals of all modulators have been combined down to a single output.

It is important that the signal level of each of the channels at point "X" is exactly the same or atleast within 1 dB of each other. The absolute signal level is unimportant. There is no magic value or recommended signal level at point "X". The final signal level at point "X" will depend largely on the maximum output capability of the modulators used. As an example, let us consider the block diagram in figure 1. Each 4 Way Splitter will present an 8 dB loss, between its output and input. Tracing the first channel we see that it passes through two 4 Way Splitters i.e. a total loss of $8 + 8 = 16$ dB.

If the modulators used are capable of a maximum output level of 95 dB and are actually set for an output of 92 dB, the signal at point "X" would be $92 - 16 = 76$ dB. Similarly, if the modulators are capable of a maximum output of 105 dB but set to actually provide 100 dB, the output level at point "X" will be $100 - 16 = 84$ dB.

Do note that this does not imply that the output level of all modulators is equal ! The output signal from each modulator under goes attenuation or a loss as it passes through the various Splitters / Combiners. If the combination of Splitters / Combiners is unsymmetrical then the output signal from each modulator will undergo different levels of attenuation before it reaches point "X". The important issue is to ensure that the signals of all channel are exactly the same at the same at point "X" i.e. after passing through the combiner.

HEADEND AMPLIFIER

If, after combining the signal levels at point "X" are inadequate, you may introduce a CATV Amplifier immediately after point "X" to boost the signal output level. It is strongly recommended that a hybrid amplifier be used in this position, even for Headends with 12 or 18 channels. The amplifier in this location is required to provide both a high output level and low distortion and therefore a hybrid amplifier is an ideal solution. Keep in mind that any distortion generated at the Headend will only be multiplied again and again at each of the distribution amplifiers, before it reaches the final subscriber.

Hence the higher cost of a hybrid amplifier in this critical location is well justified even for small Headends.

As highlighted in other articles in this magazine, it is strongly recommended that the output level of any Hybrid amplifier should not exceed 100 dBu. Any increase beyond this output level will severely degrade the picture due to rapidly increasing distortion (distortion increases by 2 dB for every 1 dB increase in output level !). **MULTIPLE OUTPUT TRUNKS**

Often, more than 1 trunk distribution line is required from each Headend, for example, if one distribution line is to go North and the other South of the Headend. Two or more trunk lines can be easily generated by using an output Splitter after the Amplifier. This is shown separately in Figure 5.

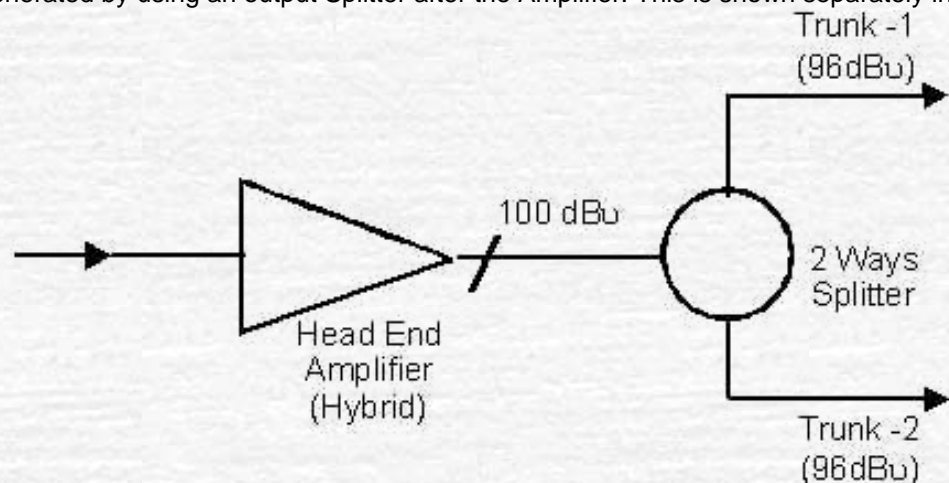

Sometimes networks have used separate Amplifiers for each of the emerging trunks. This is shown in Figure 6. While both options i.e. Figure 5 or Figure 6 are technically acceptable, only a single amplifier is used in the configuration of Figure 5. This obviously reduces the overall cost. However as shown in Figure 5, the output at each trunk will be reduced by the loss of the Splitter used. Therefore if a 2 Way Splitter is used in Figure 5, the output at each of the trunks would be 98 dBu. If a 4 Way Splitter is used, the output would be 92 dBu.

As indicated earlier keep in mind that the Hybrid Amplifier output level should not exceed 100 dB for any channel. This will maintain low distortion levels and optimum picture quality to subscribers down the line.

SYSTEM SLOPE

Readers have repeatedly requested for advice on setting up the system slope. We therefore plan to address the issue of slope in a separate article in the magazine, over the next few months. It will however suffice to recommend that a zero or flat system slope be maintained at the Headend output i.e. all channels at point "X" or if an amplifier is used, at the output of the Headend amplifier, should be exactly equal or within 1 dB of each other.

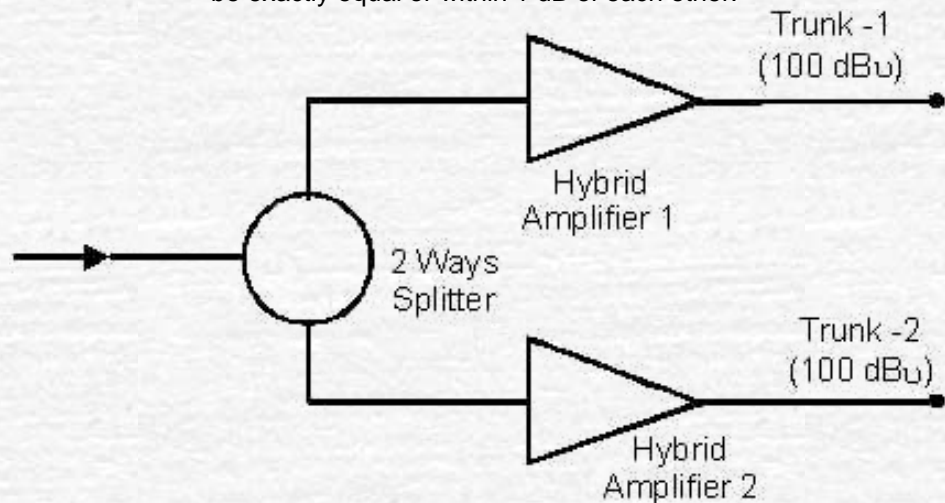

CONCLUSION

This article provides a block diagram for setting up a Headend with any configuration of any number of channels in the forward path. The block diagram is scaleable and can be changed to meet specific user requirements.

If a specific channel Combiner is not available, channels can be combined equally well using regular CATV Splitters in reverse. The key considerations are that all channels must be mixed or combined so that the output level is the same for all channels.

There is no specific or universal optimum level of signal output either for the Headend or each modulator. This would depend largely on the output level capabilities of the specific modulators used. Following these simple rules will yield an optimally set-up CATV Headend.

 [Email Us](#)